

Economic Style Electric Actuator ITQ Series

NEW



INNOBIZ
기술혁신형중소기업



ECONOMIC TYPE ITQ ELECTRIC ACTUATOR

ITQ 0020

- Suitable for small 1" ball valve automation.
- Very high efficiency & cyclic life.
- Free voltage (85~265 VAC, 1Phase) and optional 24VAC/DC
- Very compact and light weight.



PG11 Cable Gland with Wires

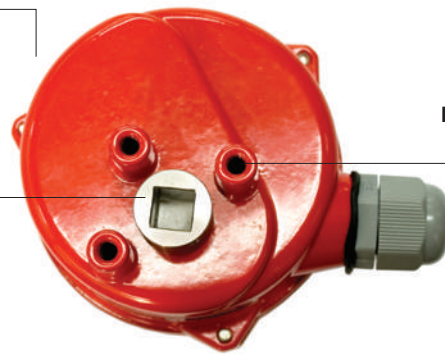

ISO F03 Flange

11X11mm
Square Female Shaft
with insert 9X9mm

PERFORMANCE

Model	Rate torque (Nm)	Duty cycle (%)	Operating time		Stem Adaption (Square Female shaft)	Rated current				Motor insulation class	Weight (kgs)
			50Hz /60Hz	24DC(No Load)		24V		1Phase			
ITQ 0020	25	50	11	11	11 X 11 mm	AC 0.60	DC 0.55	110 0.16	220 0.08	E	1

STANDARD SPECIFICATION

Enclosure	IP66, O-ring Sealed
Main Power	Free Voltage(110/220VAC/1Ph/50/60Hz) 24 VAC/DC
Duty cycle(on-off)	S2 : 50%
Motor	DC motor
Limit switches	2 ea for Open & Close (5A, 250VAC)
(Option) Extra Limit switches	Relays for Open & Close (5A, 250AC)
Mounting	ISO F03, 11 X 11 - DP12 Square female Shaft with insert 9X9mm
Travel angle	90°C ± 5°C
Cable entry & Wiring	1-PG11 Cable gland with wires 30cm long
Surface protection	Polyester coating
Ambient temperature	-10°C~ + 65°C
Humidity(R.H)	90%

WIRING

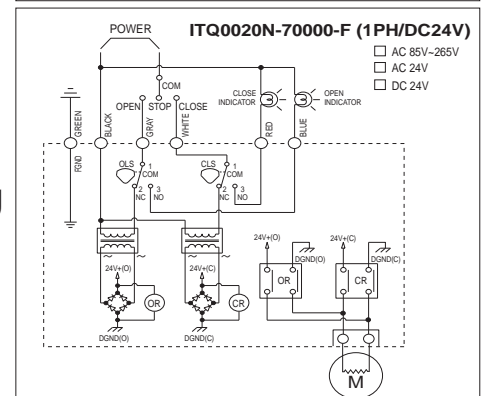
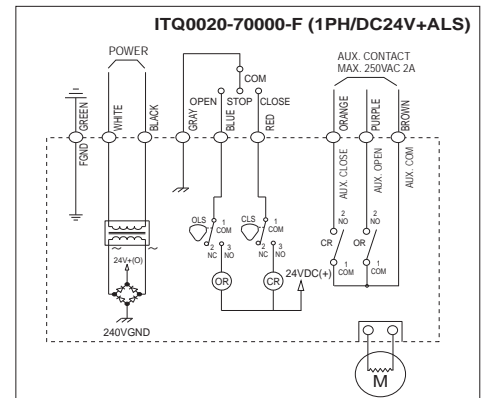

NEW ITQ 0040

- Suitable for on-off small ball / plug valves and damper automation.
- By combination of spur gears, provide very high efficiency
- The motor is a specially designed induction motor that produces high starting torques and thermally protected from overheating.
- Manual operation by Hex Wrench and dome position indication
- Compact and light weight.
- High duty cycle.

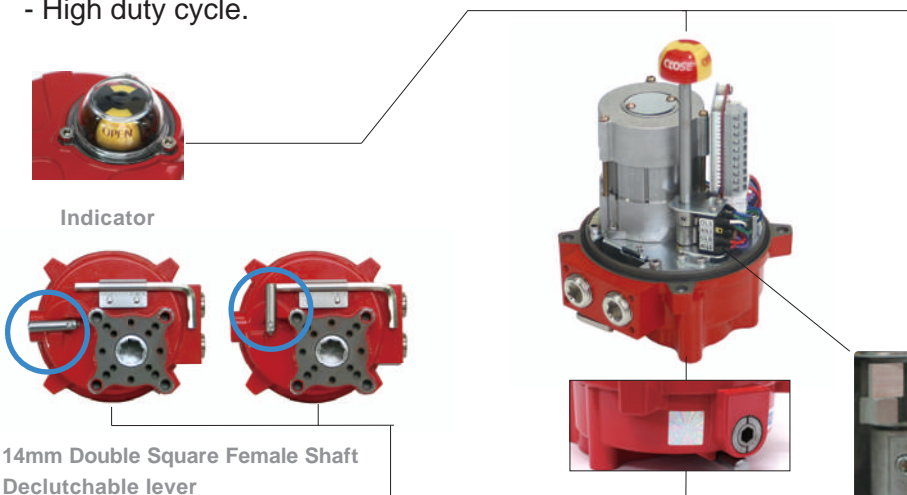

Indicator

14mm Double Square Female Shaft
Declutchable lever

Manual
Hex Wrench

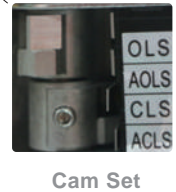

Cam Set

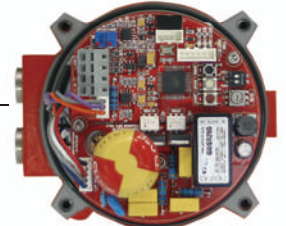

RPC (Option)
(Remote Position Controller)
Input & Output Signal
4~20mADC

PERFORMANCE

Model	Rate Torque (Nm)	Duty Cycle (%)	Operating Time (Sec.)			Stem Adaption (Double Square Female Shaft)	Rated current (A)			Motor Insulation Class	Weight (kgs)	No of Handwheel Turn
			50Hz	60Hz	DC24V (No Load)		1Phase AC		DC			
							110V	220V				
ITQ 0040	40	50	16	13	7	14X14mm	0.27	0.21	0.8	B	2.5	6

STANDARD SPECIFICATION

Enclosure	IP67, O-ring Sealed
Main Power	110/220VAC/1Ph/50/60Hz, 24VDC
Duty cycle(on-off)	S2 : 30 min
Duty cycle(modulating)	S4 : 50%
Motor	Induction motor
Limit switches	2 ea for each travel
Space heater	2W
Manual operation	Declutchable Lever & shaft on bottom
Indicator	Continuous Mechanical position indicator
Mounting	ISO F03/F04/F05/F07 flange with double square female shaft
Travel angle	90° ± 5°
Cable entries	2-M20×1.5(option : 2-PF(PT)½")
Terminal block	Spring loaded push type
Surface protection	Anodized polyester coating
Ambient temperature	-20°C~+70°C
Humidity(R.H)	90%

WIRING

ITQ 0040 110/220 ON/OFF

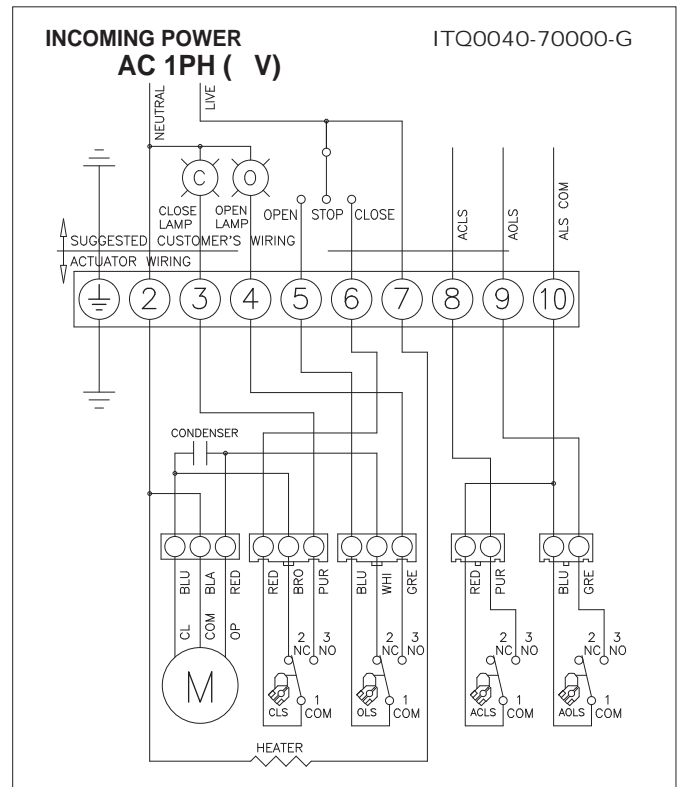

ECONOMIC TYPE ITQ ELECTRIC ACTUATOR



ITQ 0080

- Newly designed and developed for especially small ball & plug valves and damper automation.
- Self locking combination of spur and worm gears that require no brake
- The motor is a specially designed induction motor that produces high starting torques and thermally protected from overheating
- Mechanical Stopper bolts to prevent from over travel
- Easy set cams without special tool.
- Manual operation by wrench directly to the worm gearbox and dial position indication

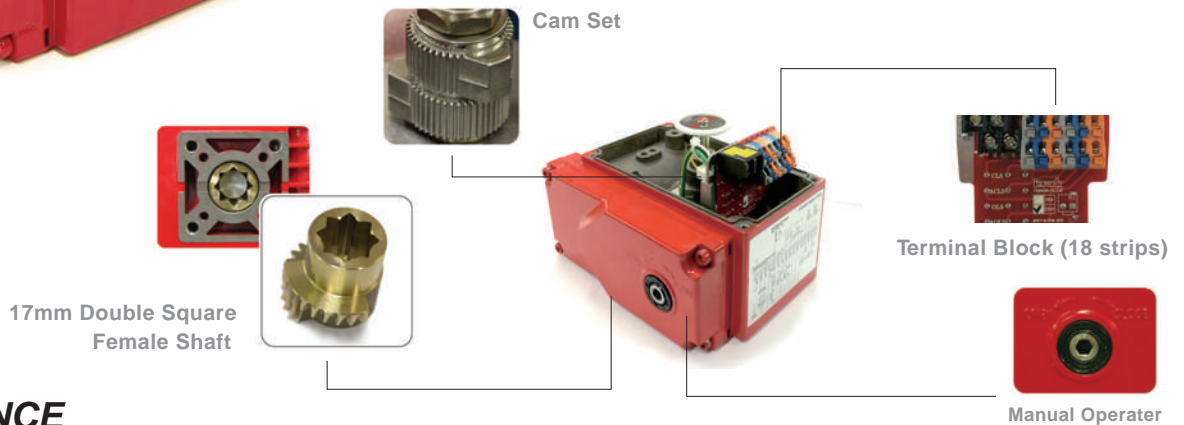

PERFORMANCE

Model	Rate torque (Nm)	Duty cycle (%)	Operating time			Stem Adaption (Double square Female shaft)	Rated current				Motor insulation class	Weight (kgs)	No of handwheel turn	
			50Hz	60Hz	24DC (No Load)		1Phase		3Phase					DC 24V
							110	220	380	440				
ITQ 0080	80	50	16	14	12	17X17mm	0.97	0.52	0.52	0.56	3.8	E	3.5	7

STANDARD SPECIFICATION

Enclosure	Weatherproof IP67, O-ring sealed
Main Power	110/220VAC/1Ph/50/60Hz, 380/440VAC/3Ph/50/60/Hz,24VDC
Duty cycle(on-off)	S2 : 40%, Max 30 minutes
Duty cycle(modulating)	S4, 50%, 1200 start/Hour
Motor	Induction motor
Limit switches	2 ea for each travel end (1 each as dry contact)
Space heater	3W
Manual operation	By wrench (M6) directly to the worm gear
Indicator	Continous Mechanical position indicator
Mounting	ISO F05 & F07 flange with double square female shaft
Self locking	By means of worm gearing
Travel angle	90° ± 10° by external adjustable mechanical stopper
Cable entries	2 - M20 X 1.5 (option : 2- PF1/2)
Terminal block	Spring loaded push type
Surface protection	Anodized & polyester coating
Ambient temperature	-20°C~+70°C
Humidity(R.H)	90%

OPTION AVAILABLE (0080 Only)

CT	-Current transmitter (output signal : 4-20mA)
	-Zero / Span Adjustment
RPC	-Remote position controller (by input and output signal)
	-Input : 4-20mA, 0-10VDC, 2~10VDC, 1~5VDC, 0~5VDC
	-Output : 4-20mA
	*Option : 0-10VDC, 2~10VDC, 1~5VDC, 0~5VDC
	-Auto-calibration
	-Reverse operating direction

DIMENSIONAL DRAWING

ITQ 0020

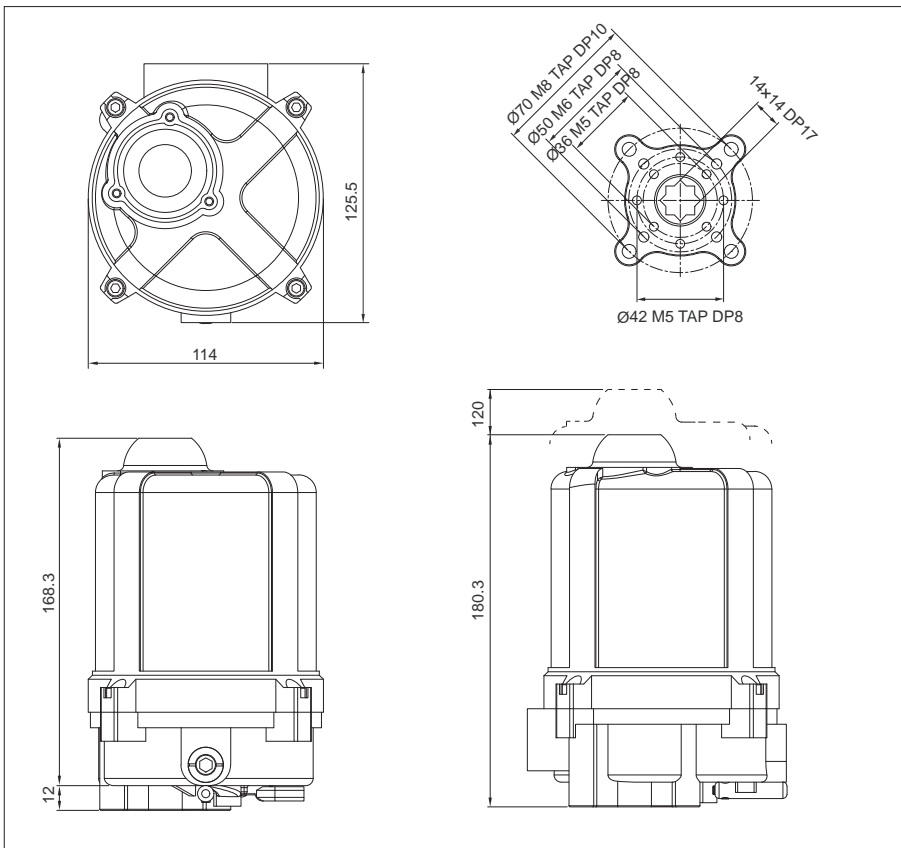
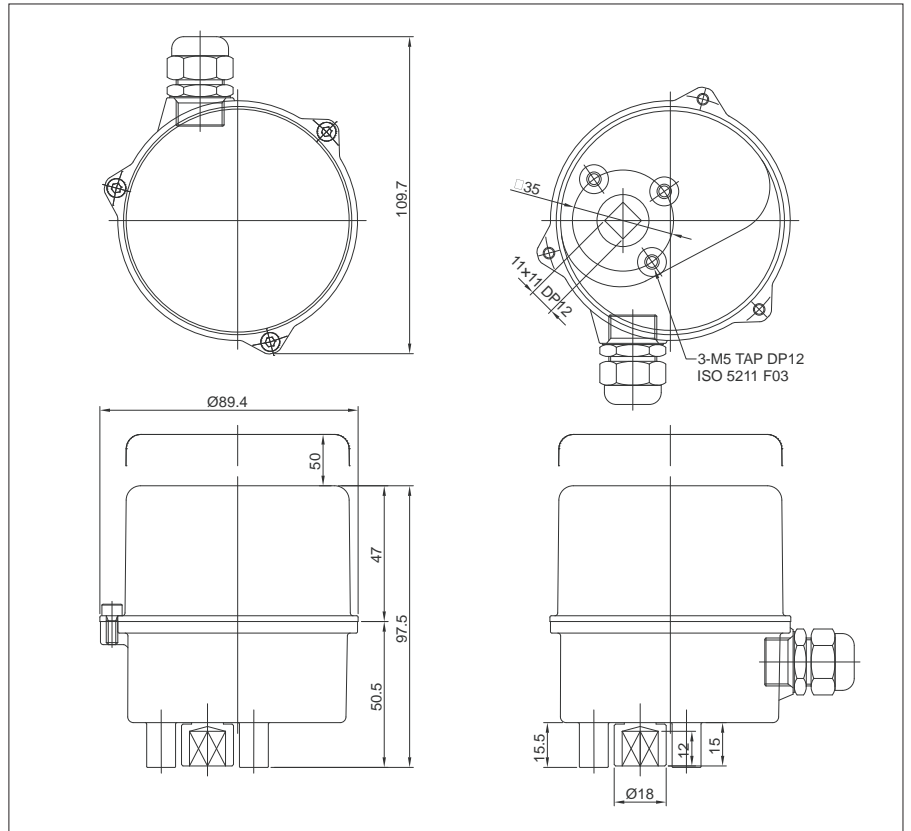

NEW ITQ 0040



ECONOMIC TYPE ITQ ELECTRIC ACTUATOR

DIMENSIONAL DRAWING

ITQ 0080

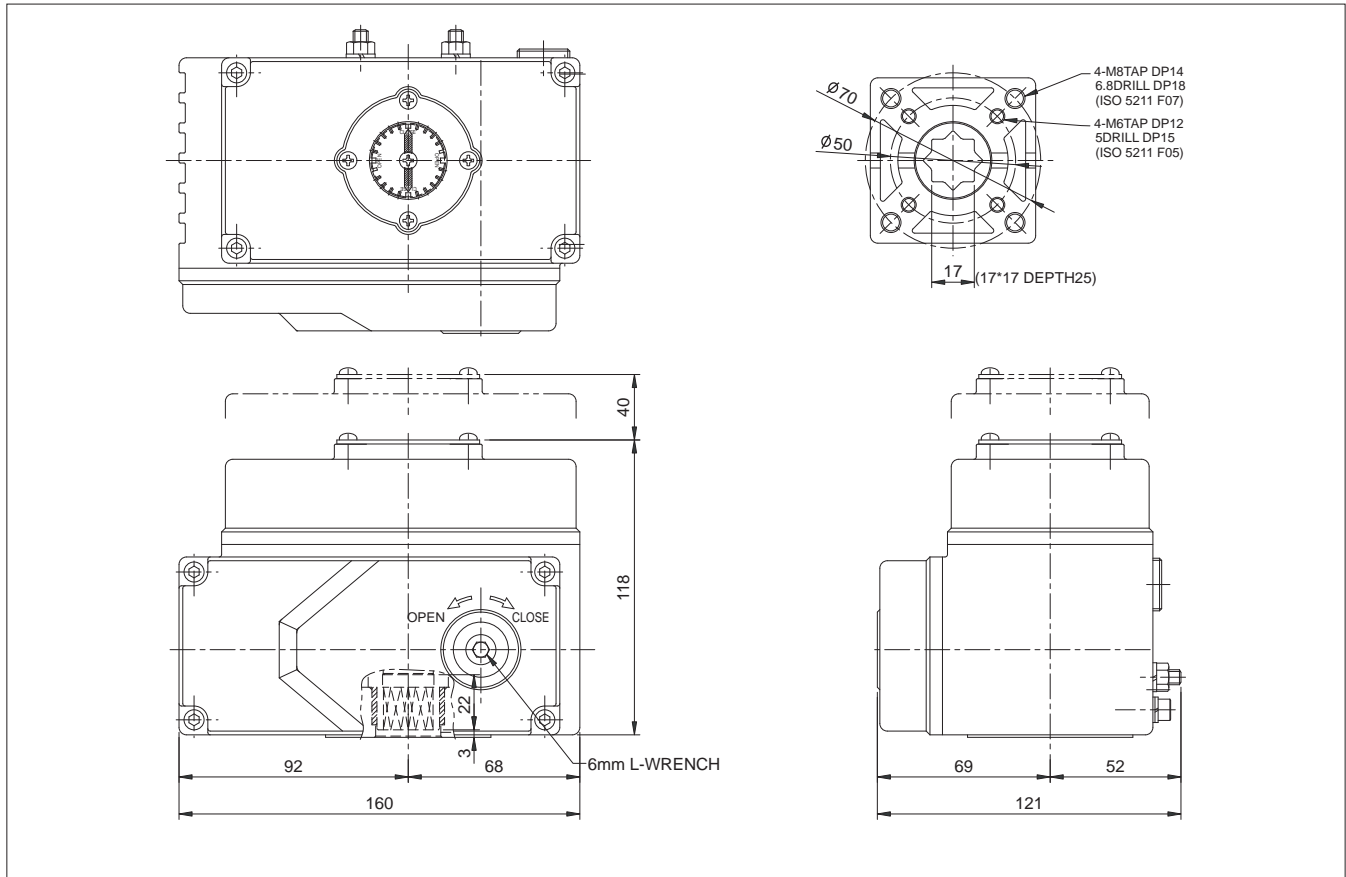

WIRING

ITQ 0080 110/220 (On-Off)

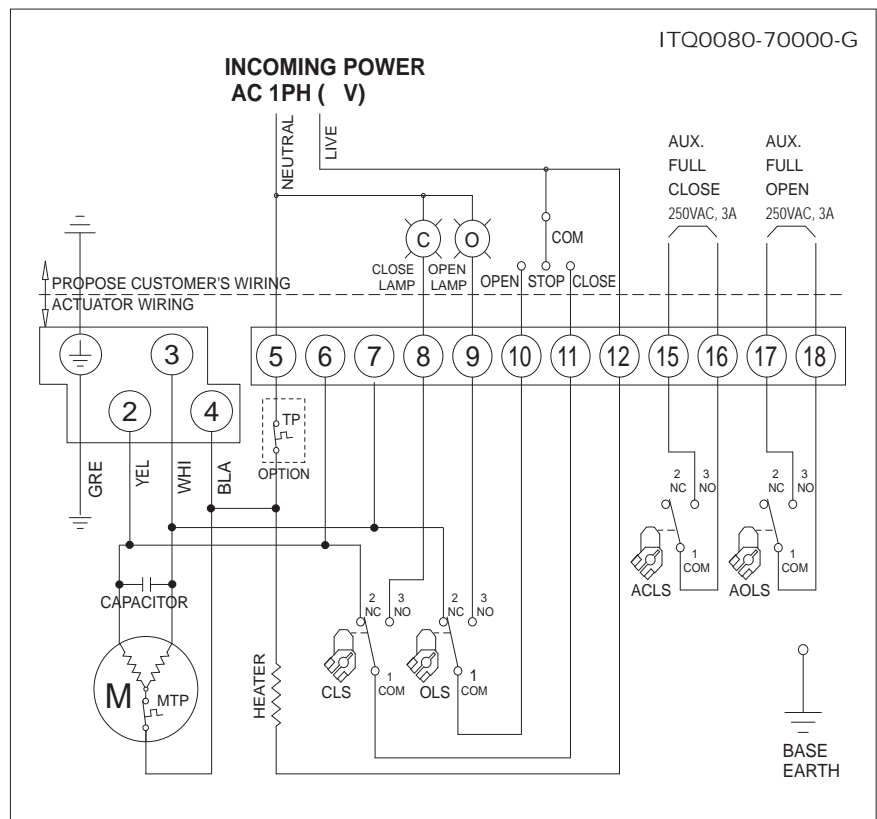

WIRING

ITQ 0080 380/440 ON/OFF

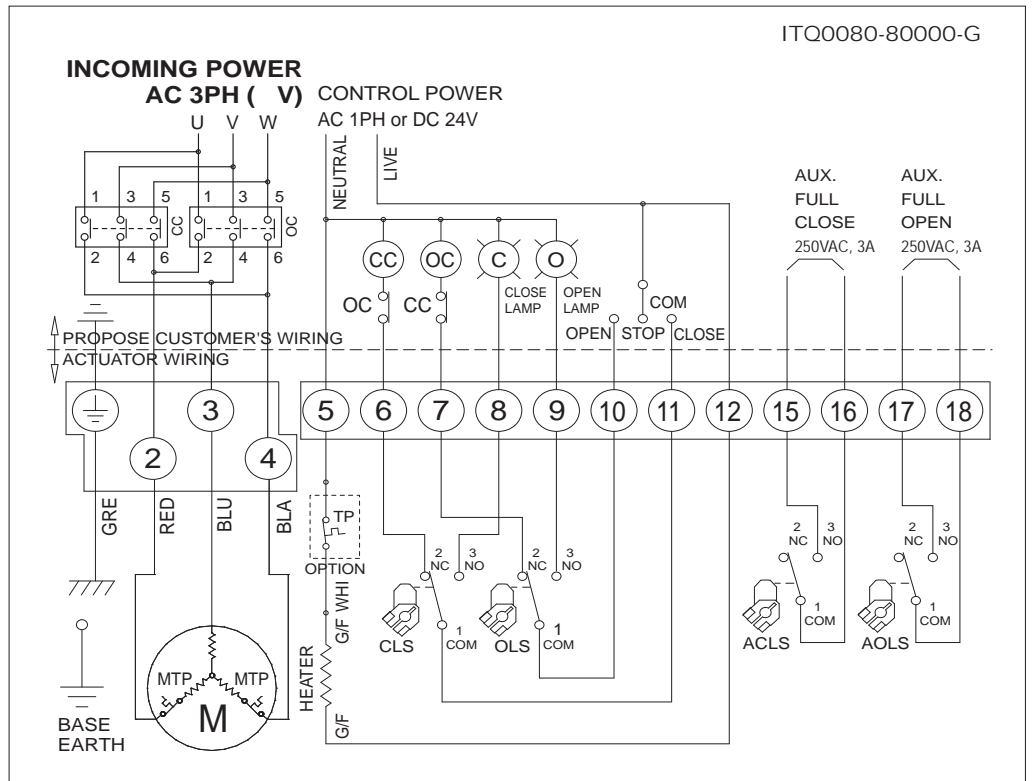

ITQ 0080 110/220 RPC

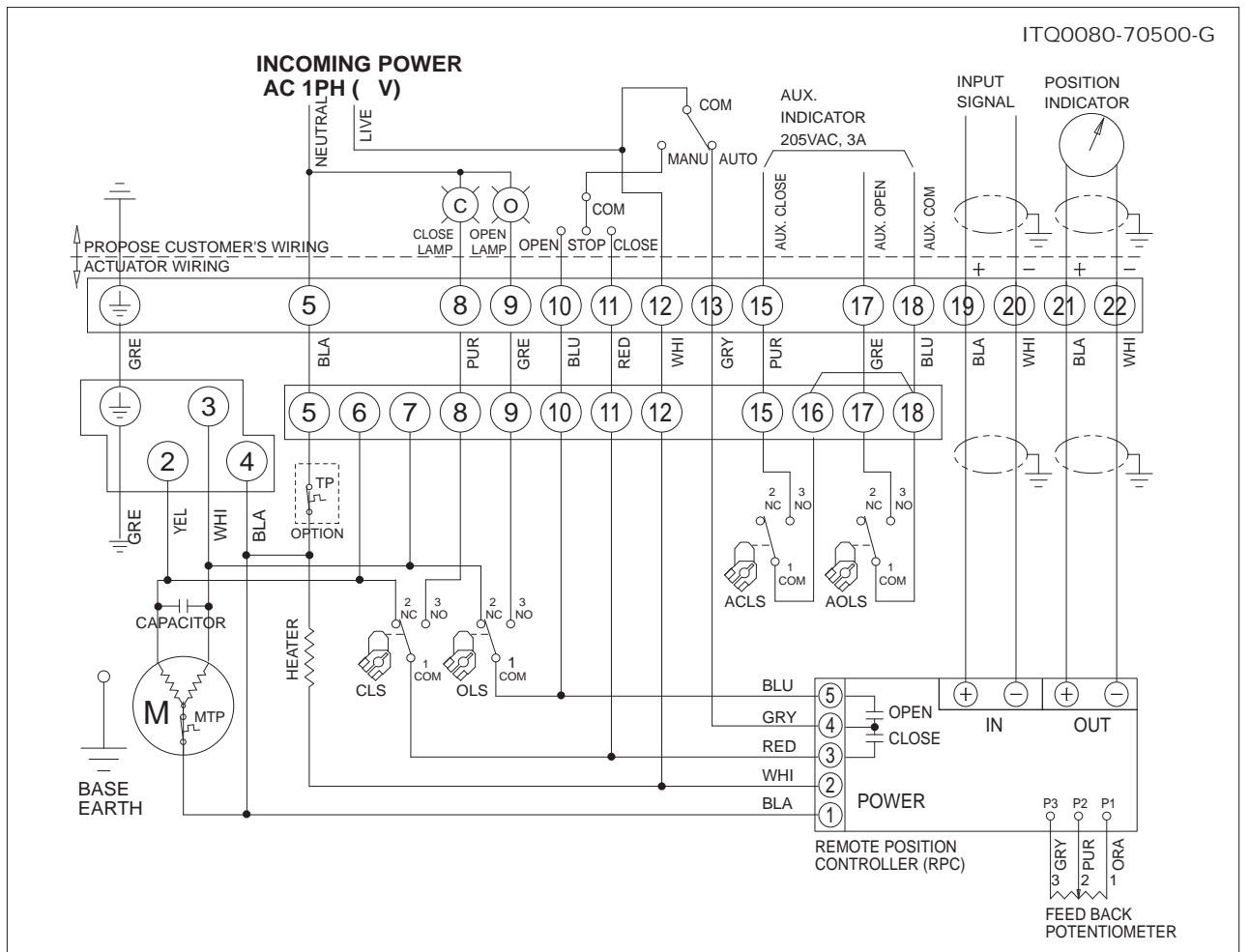

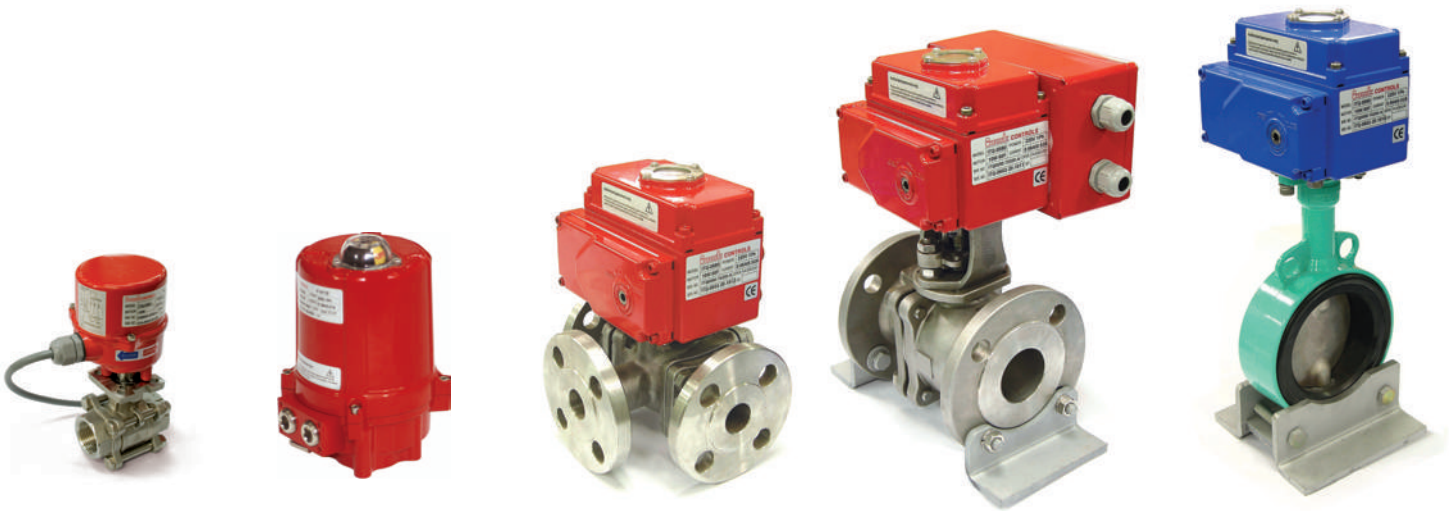

The details of this catalog are subject to change without prior notification.

i-tork[®] CONTROLS Co., Ltd.

Website : <http://www.i-tork.com>